

6. System Cost After NYSERDA Incentive:

Total System Cost	(-) NYSERDA Incentive	Total Net System Cost
\$158,340.00	\$42,630.00	\$115,710.00

7. Major Equipment Proposed:

Brand of PV Modules	Evergreen Solar	Model of PV Modules	ES-A-210
Brand of Inverter	SMA	Model of Inverter	SMA 7000, 3000
Brand and Model of Mounting Equipment	Roof Mounted Racking System		
Brand and Model of Batteries	N/A		

8. Estimated Annual Output:

Estimated Annual Output in kWh	23,560
--------------------------------	--------

Owner and Customer understand that the System output is dependent upon climatic conditions which are naturally variable, and therefore the actual output of the System over any consecutive twelve (12) month period may be higher or lower than the Estimated Annual Output stated above.

9. Equipment Location:

Location of Inverter and PV System Meter	As Shown on Site Plan attached to the Lease ("Site Plan")
Location of DC Disconnect	As Shown on Site Plan
Location of Utility Lockable AC Disconnect	As Shown on Site Plan

Owner and Customer understand and agree to the appearances, locations and mountings as described above.

10. Installation of the System:

System Type	Net Metering	Battery (Yes/No)	Mounting Type
Grid Connected	Yes	No	Roof

Installer agrees to install the System on the Installation Location. Installer agrees that any equipment used for the System shall be new equipment and that any installation shall not commence prior to the approval of Installer's NYSERDA PON-2112 Solar PV Program incentive application. Except for any obligations which are explicitly and specifically set forth herein, Installer is responsible for the installation of a fully operational System for Owner, which generates and delivers energy to the point of interconnection for use by Customer.

In connection with the installation of the System, Installer agrees as follows:

- (i) all work shall be completed in compliance with all building codes and other applicable laws, including the New York State Building Code and the National Electrical Code, and to the extent required by law, shall be performed by individuals duly licensed and authorized by law to perform the work;
- (ii) all components will be UL, or CSA, or ETL or similarly listed as required by NEC;
- (iii) shall, at its own expense, obtain a building permit, if required, and electrical inspections necessary for the work to be performed;
- (iv) in the event the System is a ground mount system or otherwise requires excavation, the Contract Price, as defined in Section 3, does not include the excavation of any excessive rock or any bedrock by Installer;
- (v) shall install and initiate operation of the System in compliance with all applicable distributed generation laws and rulings in effect at the time of the installation, but will have no liability for future possible changes to such laws or rulings or their affect on the operation of the system; and
- (vi) upon completion of the installation of the System, Installer will remove all debris accumulated by the installation and rough grade over any excavation work.

Installer may at its discretion engage subcontractors to perform work hereunder, and Installer will fully pay such subcontractors and in all instances remain responsible for the proper completion of the installation of the System and compliance with this Agreement. All change orders shall be in writing and signed both by Owner and Installer, and shall be incorporated in and become a part of this Agreement.

Owner and Customer understand that the System is a Grid-Intertie Photovoltaic Generating System that is required by state and utility company regulations to disconnect and shut down in the event of a utility or electric grid failure, and will not provide back-up power in the event of such a failure.

11. Payment Schedule:

In consideration for Installer's installation of the System, Owner agrees to pay to Installer the system cost as further described in Section 3 (the "**Contract Price**"). The full Contract Price shall be paid within thirty (30) days of the System achieving substantial completion of the construction of the System so that it becomes fully operational and commences generating energy and delivering it to the point of interconnection for use by Customer. In the event that the total Contract Price is not received in accordance with the terms hereof, Installer reserves the right to lock the System in a turned off, non-functioning position, and pursue any other remedies until full payment is received.

Owner has relied upon Installer to include any and all costs associated with the complete installation of the System to be included in the Contract Price. In the event that additional costs are required by Installer, Installer shall submit a written request to Owner explaining the reason for such additional costs and the additional amounts that are being sought. Installer and Owner shall make reasonable efforts to agree on a change order and revised Contract Price. If the parties are unable to come to an agreement within thirty (30) days of written notice, Installer may cancel the Agreement without penalty. Upon such cancellation, Owner shall fully refund any amounts paid by Installer, less any reasonable fees and expenses incurred by Installer.

12. Title:

The Parties hereto agree that title to material, supplies, equipment and other goods covered by this Agreement will pass to Owner upon receipt by Installer of the full Contract Price. In addition, Installer will take all necessary steps to assign all manufacturers' warranties for the System to Owner.

Title to all the material, supplies, and equipment incorporated or to be incorporated into the System shall be free and clear of all liens, claims, security interests or encumbrances and Installer warrants and shall defend such title, at its sole expense, against the claims of third parties. Installer shall immediately notify Owner of the assertion of any lien or encumbrance upon the System or any part thereof.

13. Eligibility to Receive NYSERDA Incentive:

The parties hereto agree and acknowledge that Installer is a NYSERDA Eligible Installer and is eligible to receive the NYSERDA incentive rebate as shown above pursuant to NYSERDA PON-2112. Customer is an electric distribution customer of a local electric provider who contributes to the Renewable Portfolio Standard/System Benefits Charge. Any and all incentive amounts received from the NYSERDA PON-2112 Solar PV Program will be applied in its entirety to Owner's system cost.

14. Termination:

In the event that (i) Installer fails to submit a completed Incentive Application to NYSERDA, (ii) the Incentive Application is not approved by NYSERDA, (iii) the NYSERDA Incentive received by Installer is less than the amounts provided in Section 5 hereof, or (iv) the structural framing of the Installation Location's building does not support the installation of solar panels and ballasts, Owner or Installer may, prior to the start of the installation and at its sole discretion, terminate this Agreement without penalty and any payments made by Owner or Installer will be refunded less any reasonable fees and expenses.

The parties agree that Owner or Installer may terminate this Agreement with no liability in the event that the local electrical utility denies acceptance of the System's interconnection due to area network restrictions. Customer agrees to use commercially reasonable efforts to assist Owner and Installer in entering into a metering agreement with the local electrical utility.

15. System Warranty:

Installer warrants the full System for five (5) years to Owner and Customer (the “**System Warranty**”), which shall commence upon the completed installation of the System and receipt of NYSERDA’s final approval. Installer warrants that the System (i) has been installed in accordance with prudent industry standards and this Agreement, (ii) shall be free from defects in design, materials and workmanship under normal operating conditions, and (iii) at the time of completion, the System shall be in material compliance with applicable law. The System Warranty covers all components of the System against breakdown or degradation in electrical output of more than ten (10) percent from their original rated electrical output. The System Warranty is limited to repair or replacement of defective components or sub-systems of the System by Installer or its subcontractor.

The System Warranty is limited to the actual System installed by and work performed by Installer and its subcontractors. This System Warranty does not cover intentional or accidental damage, malfunctions or service failures caused by (i) the failure of Owner or Customer to operate and maintain the System in accordance with manufacturer’s warranties and prudent industry standards, or (ii) acts of God, floods, storms, lightning, fires, or actions by any federal, state, or local governmental authority.

Owner and Customer agree to maintain the System in proper operating condition in accordance with manufacturer’s warranties, as provided by Installer, and prudent industry standards. Owner and Customer shall report any malfunction as soon as it is noticed to Installer.

16. Insurance:

Installer represents that it has purchased and has kept in force commercial general liability insurance, commercial automobile liability insurance and workers compensation insurance. Installer will provide evidence of this insurance to Owner or Customer upon request.

17. Environmental Attributes:

Customer, Owner and Installer acknowledge and agree that Owner will retain ownership of all Environmental Attribute(s), as defined in Section 5 of the Equipment Lease, subject to NYSERDA’s interest in any REC associated with the System’s energy production.

18. Data Monitoring and Reporting:

Customer agrees to take readings measuring the energy generation by the System every six (6) months for the first three (3) years of the System’s operation. All such readings and measurements taken pursuant to this Section shall be delivered to Installer in order to be submitted to NYSERDA. Notwithstanding the foregoing, the Parties may agree that either Owner or Installer is responsible for taking such readings or measurements.

19. Access to the System:

Owner and Customer each agree that it will provide (i) NYSERDA or its representative with reasonable access to the System for inspection purposes, provided that NYSERDA shall provide Owner and Customer with three (3) days written notice of such inspection, and (ii) Installer or its representatives with reasonable access to the System in order to for Installer to

conduct inspections and/or System maintenance during the 5 year warranty period.

20. Customer Acknowledgments:

In connection with the installation of the System, Customer acknowledges and agrees as follows:

- (i) NYSERDA and its representatives are permitted reasonable access to the System for inspection purposes and Owner and Installer are permitted reasonable access to the System for inspection and maintenance purposes, pursuant to the limitations set forth in Section 18;
- (ii) Customer shall be responsible for any costs associated with bringing any building or structure that the System will be installed on at the Installation Location up to code in order to pass building and electrical inspections and obtain necessary permits and for any costs associated with structure upgrades required, as determined by Installer, to support the System. If Customer determines the upgrade costs are prohibitive, they may terminate the contract before the start of installation without penalty.
- (iii) NYSERDA will hold the title to any Renewable Energy Credit ("REC") associated with the System's energy production for three (3) years from the date of System operation, pursuant to the terms of the NYSERDA PON-2112 Solar PV Program;
- (iv) Customer shall enter into the Equipment Lease with Owner; and
- (v) Installer has permission to take images (including motion picture or still photographers) of the System at the Installation Location for any purposes, including advertising, promotion and marketing.

21. NYSERDA Terms and Conditions:

NYSERDA's website www.powernaturally.org contains information on NYSERDA and the funding program under which support for this System will be requested. Customer and Owner understand that neither NYSERDA nor the State of New York: (1) endorse any Eligible Installer, or (2) guaranty, warranty, or in any way represent or assume liability for any work proposed or carried out by an Eligible Installer. Additionally, NYSERDA is not responsible for assuring that the design, engineering and construction of the project or installation of any the System is proper or complies with any particular laws, regulations, codes, licensing, certification and permit requirements, or industry standards. NYSERDA does not make any representations of any kind regarding the results to be achieved by the System or the adequacy or safety of such measures. NYSERDA will not make any payment of the incentive rebate to Installer without proofs that all required permits and approvals have been obtained. The Parties agree to collaborate with NYSERDA's Director of Communications should s/he prepare any press release or plan any news conference related to the System and authorize NYSERDA to use System photographs in brochures, on its website and in other print materials.

22. Governing Law:

This Agreement is governed by the laws of the State of New York, notwithstanding choice of law provisions, and any disputes arising under this Agreement shall be venued in Erie County, New York.

23. Notices

Any written notice under this Agreement shall be deemed to have been given when actually delivered. Any such written notice may be delivered personally, or deposited with a nationally recognized overnight courier service or in the United States mail, postage prepaid, addressed to recipient at the following address, or at such other address as the applicable party may request in writing:

<p>If to Installer:</p> <p>Solar Liberty Energy Systems, Inc. 6500 Sheridan Dr. Suite 120 Buffalo, NY 14221</p> <p>Phone: 716-634-3780 Email: Nathan@solarliberty.com</p>	<p>If to Owner</p> <p>Solar Liberty Electric Company, Inc. 6500 Sheridan Dr. Suite 120 Buffalo, NY 14221</p> <p>Phone: 716-634-3780 Email: AKRizzo@solarliberty.com</p>
<p>If to Customer:</p> <p>Mailing Address: Town of Ulysses 10 Elm St. Trumansburg, NY 14886</p> <p>Phone: _____ Email: _____</p>	

24. Entire Agreement; Modifications:

This Agreement and the Lease and NYSERDA's Addendum to Customer Purchase Agreement attached hereto as Exhibit A ("NYSERDA Addendum"), is the entire agreement between the Parties and supersedes all other oral and written communications and representations. In the event of a conflict between terms of this Agreement (including any and all attachments hereto and amendments thereof) and the terms of the NYSERDA Addendum, the terms of the NYSERDA Addendum shall control. Customer may, but is not required to, consult an attorney prior to entry into this Agreement or the Lease.

This Agreement shall bind the respective parties hereto, their successors, legal representatives and assigns.

Modifications to this Agreement must be made in writing and signed by all parties.

25. Assignment:

This Agreement shall be binding upon and shall inure to the benefit of, and shall be enforceable by, the Parties and their respective successors and assigns as permitted by and in accordance with the terms hereof. Installer may not assign this Agreement without the consent of Owner. Owner may assign its interest in this Agreement and sell or grant a security interest in all or any part of the System without notice to or the consent of Customer. In the event of a change in ownership or title of the Installation Location, Customer may assign this Agreement, upon notice to Installer and Owner to the new owner of the Installation Location, provided that such new owner assumes this Agreement and the Lease Agreement in writing and customer shall reimburse Owner for any loss of Environmental Financial Incentives or Environmental Attributes.

26. Counterparts:

This Agreement may be executed in two or more counterparts, each of which shall be deemed an original, but all of which together shall constitute one and the same instrument. Any signature page of any such counterpart, or any electronic or facsimile thereof, may be attached or appended to any other counterpart to complete a fully executed counterpart of this Agreement, and any telecopy, .pdf-format or other facsimile transmission of any signature of a party hereto shall be deemed an original and shall bind such party.

[Signature Page Follows]

This Agreement entered into this the 22 day of December 2011

INSTALLER:

Solar Liberty Energy Systems, Inc.

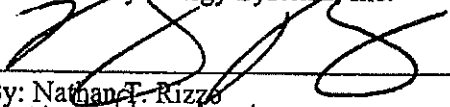
By: Nathan T. Rizzo
Its: Vice President

OWNER:

Solar Liberty Electric Company, Inc.

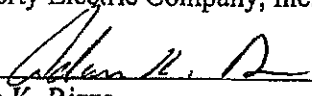
By: Adam K. Rizzo
Its: President

CUSTOMER:

Town of Ulysses



By: [Print Name] Supervisor
Its: Roxanne Marino

EXHIBIT A
NYSERDA Addendum

[Insert provisions]

PON 2112 Incentive Application Form

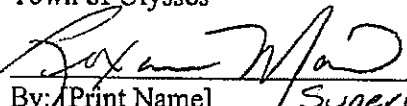
Attachment B

INCENTIVE APPLICATION FORM

Name of Eligible Installer/Installer Number: Nathan Rizzo/4116 Eligible Installer Email: Nathan@solarliberty.com
 Name of Company: Solar Liberty Energy Systems, Inc. Eligible Installer Phone: 716-634-3780
 Owner Name: Town of Ulysses Owner Phone Number: 0
 Installation Address: 3888 Colegrove Rd.
 City: Trumansburg State: NY Zip: 14886
 Mailing Address (if different from installation Address): _____
 City: _____ State: _____ Zip: _____
 Owner Email: 0 Utility Service Territory: National Grid
 Expected Date of Installation: May 1, 2012 Expected Date of Interconnection May 10, 2012
 Please attach proof of payment by customer into Renewable Portfolio Standard (as shown on utility bill or letter from utility)

Building or Customer type Check all that apply:

New Construction Existing Home Commercial Single Family
 2-4 Family Residential Multifamily Agricultural Industrial
 Educational Not For Profit Municipality/Government Other

Required System Documentation - Each Incentive Application must include as attachments: site map, shading analysis, three-line electrical drawing, and utility bill.

PV Panel Manufacturer: Evergreen Solar Model: ES-A-210 Number of Panels: 116
 PV Panel Manufacturer: _____ Model: _____ Number of Panels: _____
 Inverter Manufacturer: SMA Model: SMA 7000, 3000 Number of Inverters 4
 Inverter Manufacturer: _____ Model: _____ Number of Inverters _____
 Inverter Efficiency: 96.0% Orientation: 90 Tilt: 19
 Total System Production kW (DC at STC): 24.36 Total System Production AC: 22494.72
 Customer's Annual Electric Usage (kWh): 30427
 Expected Annual kWh Produced by System: 23560 Annual Electrical Offset Associated with the PV System: 77.43%

(Must Not Be Greater Than 110%)

Total Cost Before Incentive: \$158,340.00 Incentive Total: \$42,630.00

Incentive Calculation: 42630

Estimated Annual losses from shading: 0 kWh 0.00%
 Estimated Annual losses from orientation, tilt, etc.: 3563 kWh 13.00%
 Estimated Annual losses from shading & orientation: 3563 kWh 13.00%

Does total Square footage of PV array exceed 4,000 square feet: No

If Batteries are a part of this System, What is their capacity: No

PON 2112 Incentive Application Form

Attachment B

Clipboard Audit: The Company/Installer agrees to complete a clip board audit consisting of two main components: an interview of the home/building owners to ascertain energy use habits and the age of the building, and an inspection of the building to identify potential energy efficiency measures, especially low and no cost measures that could reduce the electricity load of the building. This would include an inspection of the hard-wired lighting systems and free-standing light fixtures, appliance ages and whether they are ENERGY STAR, the presence of advanced power strips for consumer electronics, existence of "vampire loads" related to consumer electronics and battery chargers, use of programmable thermostats or timers for air conditioners, age and condition of the doors and windows, and inquiries to the owner regarding any recent installation of insulation. The PV installer would conclude the audit with a homeowner debriefing. The installer would leave a copy of the inspection form with the owner at the end of the inspection. The form will include a description of the home, recommendations of changes to reduce electric consumption, and easy fixes the homeowner can do. The installer will also leave a list of Home Performance Contractors that could install more complex energy efficiency measures, informational brochures informing the owner of the details of utility or NYSERDA energy efficiency programs available to home owner, and a brochure of low cost/no cost tips for reducing energy consumption. The inspection should last no more than 60 minutes.

_____ (initial to acknowledge requirement and adherence).

Non residential Energy Management: The Company/ Installer will provide non-residential building owners with information on Energy

Star's Portfolio Manager Benchmarking Tool or other equivalent tool and, if requested by the building owner, assist them to enter utility bill information into the Tool in order to produce an EUI (Energy use index)6 and, where applicable an Energy Star score. The installers should also provide informational brochures on NYSERDA and utility energy efficiency programs. Customers will not be required to benchmark or implement energy efficiency measures as a pre-requisite to receive a PV incentive. RM (initial to acknowledge

REQUIRED APPLICATION DOCUMENTATION: Each Incentive Application must include all documentation listed on the attached checklist.

If batteries are part of this system, what is their capacity? _____

CERTIFICATION STATEMENT: I certify that all information provided in this application, including worksheets, analysis, permits and approvals is true and correct to the best of my knowledge.

Installer Signature [Signature] Date 12/22/2011

Print Name Nathan Rizzo

Company Signature [Signature] Date 12/22/2011

Print Name Nathan Rizzo

Customer Signature Roxanne Marino Date 12-22-11

Print Name Roxanne Marino; Supervisor, Town of Ulysses

For Internal Use Only
Date Received by NYSERDA _____
Completed Form and All Required Attachments Yes No
Approved Denied Date:
Signature:

PON 2112- Solar PV Program

Attachment E

ADDENDUM to the CUSTOMER PURCHASE AGREEMENT

All Customer Purchase Agreements must include an executed copy of this Addendum to be eligible to apply for Solar PV Program Incentives. The Eligible Installer is identified as "Installer", the Customer or Owner is identified by "Customer", and the Eligible Installer's Affiliated Entity is identified as the "Company".

Solar PV Program Incentives are only available for the installation of new equipment and PV Systems that have not been installed (partially or completely) prior to NYSERDA approval of the Incentive Application. Incentives will not be provided directly to the Customers but are paid to the NYSERDA Eligible Installer, who must then apply the entire approved amount to the Customer's system cost. The Final Invoice Checklist, completed and signed by the Installer and Customer at the time of commissioning, must accompany the Final Incentive Payment Form submission.

Review of System Design NYSERDA will review the design of the PV System considering issues including, but not limited to, system layout, orientation, shading, expected output, etc. NYSERDA approval of the Incentive Application is contingent on adherence to the proposed system design. Installers must receive approval from NYSERDA for any material modification of the proposed system or its components, or the incentive may be revoked.

All potential system output losses (after all equipment losses are applied) associated with shading, system orientation, tilt angle, etc. may not exceed 20% of optimal system output to receive the full incentive. Such losses must be detailed in each application package using industry accepted shading and orientation tools, verifiable assumptions and calculations. System with losses greater than 20% of optimal output due to shading and orientation issues may be considered on a case-by-case basis. However, any available incentives for these systems will be prorated by output loss. In cases where trees or any other obstruction must be removed or moved in order to meet the program rules, incentive payments will not be made until the obstructions are removed and a new shading analysis and photos have been submitted and reviewed by NYSERDA. Any trees or obstructions must be clearly labeled in the site map.

Qualified Customers: Incentives are available to electricity distribution customers of Central Hudson Gas & Electric Corporation, Consolidated Edison Company of New York, Inc., New York State Electric & Gas Corporation, Niagara Mohawk Power Corporation, Orange and Rockland Utilities, Inc. and Rochester Gas and Electric Corporation who contribute to the Renewable Portfolio Standard/System Benefits Charge (sometimes referred to as "RPS/SBC" as a line item on bills).

Warranty: Both the Eligible Installer and the Affiliated Entity shall offer a full transferable warranty to the purchaser of the PV System installed under this Customer Purchase Agreement for a period of (5) years after the Eligible Installer has completed the installation and NYSERDA's final approval has been provided. This warranty covers all components of the system against breakdown or degradation in electrical output of more than ten percent from their original rated electrical output. This warranty covers the full costs including labor and repair or replacement of defective components or systems. If a battery back-up is installed under this Agreement, the Eligible Installer and the Affiliated Entity shall offer a full warranty to the purchaser for the battery system for a period of 2-years after installation. This warranty covers the battery system against breakdown and covers the full costs.

Title to Renewable Energy Credits: Renewable Energy Credits (RECs), which may also be referred to as green power attributes or tradable renewable credits (TRCs), are the environmental benefits associated with electricity that is generated from renewable sources such as wind or solar.

PON 2112 Incentive Application Form

Attachment E

Funding from New York State's Renewable Portfolio Standard (RPS) contributed to develop the PV System identified in this Customer Purchase Agreement. The parties acknowledge that for the first three years of operation of the PV System funded under this program, NYSERDA will hold title to the RECs.

Data Monitoring and Reporting: For a period of three years, the Installer NTI Customer _____ (Please designate and initial) must take readings measuring the energy generation of the PV System every six months. For systems 25 kW and higher meter readings must be taken monthly and reported to NYSERDA every six months for the three year monitoring period. While the customer may be responsible for taking meter readings, all meter readings must be submitted to NYSERDA by the Eligible Installer.

Quality Control: For quality control purposes, Customer must provide NYSERDA or its representative with reasonable access to the PV System for inspection purposes. Final incentive payments may be contingent on NYSERDA inspection of the installed PV System.

Publicity and Site Events: Customers and Installers are required to collaborate with NYSERDA's Director of Communications should they prepare any press release or plan any news conference related to the PV System. NYSERDA is authorized to use the PV System photographs in brochures, on its website, and in other print materials.

Tax Incentives: Customers are encouraged to consult the IRS (see www.irs.gov), the NYS Dept. of Taxation and Finance (see www.tax.state.ny.us) and with an accountant/tax advisor for details on eligibility for the credit provided in the law, regardless of whether the Installer has provided information regarding the expected tax benefits (real property, federal or state tax incentives, or sales and use tax exemptions).

Cost Estimate/Total System Price: The Customer has relied upon the Company/Installer to include any and all costs associated with the complete installation of the proposed PV System in the Customer Purchase Agreement. If additional costs are sought from the Customer, the Customer Purchase Agreement may be cancelled without penalty and the customer may seek a full refund of any deposit paid to the Company/Installer or costs the Customer incurred under this Agreement, less any reasonable site visit fees charged by the Company/Installer.

Incentive Estimate: If the Installer does not submit a completed Incentive Application to NYSERDA, or if the Incentive Application (a) is not approved by NYSERDA or (b) if NYSERDA approved a lower incentive, the Customer may terminate this Customer Purchase Agreement without penalty and seek a full refund of any deposit paid to Installer or costs he or she incurred under this Customer Purchase Agreement, less any reasonable site visit fees charged by the Company/Installer.

PV System completion/commissioning: The Company/Installer agrees to complete the installation of the PV System, and request necessary inspections, within 120 days of NYSERDA's approval of the Incentive Application. Unless written approval of an extension has been issued by NYSERDA, the Company/Installer will be required to return any and all incentive payments to NYSERDA if this milestone has not been met.

Clipboard Audit: The Company/Installer agrees to complete a clipboard Audit consisting of two main components: an interview of the home owners to ascertain energy use habits and the age of the building, and an inspection of the building to identify potential energy efficient measures, especially low and no cost measures that could reduce the electricity load of the building. This would include an inspection of the hard-wired lighting systems and free-standing light fixtures, appliance ages and whether they are ENERGY STAR, the presence of advanced power strips for consumer electronics, existence of "vampire loads" related to consumer electronics and battery chargers, use of programmable thermostats or timers for air conditioners, age and condition of the doors and windows, and inquiries to the owner regarding any recent installation of insulation. The PV installer would conclude the audit with a home owner debriefing.

PON 2112 Incentive Application Form

Attachment E

The installer would leave a copy of the inspection form with the owner at the end of the inspection. The form will include a description of the home, recommendations of changes to reduce electric consumption, and easy fixes the homeowner can do. The installer will also leave a list of Home Performance Contractors that could install more complex, energy efficiency measures, informational brochures informing the owner of the details of utility or NYSERDA energy efficiency programs available to home owner, and a brochure of low cost/no cost tips for reducing energy consumption. The should last no longer than 60 minutes. Customers will not be required to implement energy efficiency measures as a pre-requisite of receiving a PV incentive.

Non Residential Energy Assessment: The Company/Installer will provide non-residential building owners with information on Energy Star's Portfolio Manager Benchmarking Tool or other equivalent tool and, if requested by the building owner, assist them to enter utility bill information into the Tool in order to produce an EUI (energy use index) and, where applicable an Energy Star score. The installers should also provide informational brochures on NYSERDA and utility energy efficiency programs. Customers will not be required to benchmark or implement energy efficiency measures as a pre-requisite for receiving a PV incentive.

Consumer Information: New York consumers and customers are encouraged to consult the New York State Office of the Attorney General website for consumer information:

http://www.ag.ny.gov/bureaus/consumer_frauds/tips/home_improvements.html The NYS Consumer Protection Board offers additional information with the following publications:

http://www.nyconsumers.gov/pdf/home_improvement_brochure.pdf

Conflicting Terms: In the event of a conflict between the terms of the Customer Purchase Agreement (including any and all attachments thereto and amendments thereof) and the terms of this Addendum, the terms of this Addendum shall control.

Communication with Customer: Installer, Company and Customer agree that NYSERDA may, at NYSERDA's discretion, communicate by voice and/or written format with any PV System Customer with respect to any matter relevant to a proposed or installed PV System. Such communications may be in reply to an inquiry from a Customer or at NYSERDA's initiation.

Disclaimer: The Customer understands that neither NYSERDA nor the State of New York: (1) endorse any Eligible Installer; or (2) guaranty, warranty, or in any way represent or assume liability for any work proposed or carried out by an Eligible Installer. Additionally, NYSERDA is not responsible for assuring that the design, engineering and construction of the project or installation of any solar electric generation system is proper or complies with any particular laws, regulations, codes, licensing, certification and permit requirements, or industry standards. NYSERDA does not make any representations of any kind regarding the results to be achieved by the solar generation systems of the adequacy or safety of such measures.

Certification Statement: By signing, all parties certify that they have read and understand the above information and requirements and agree to abide by them. NYSERDA will not accept an application from an Installer if the date of the signed contract is over 30 days prior.

PON 2112 Incentive Application Form

Attachment E

Customer: By signing below, the customer certifies that he or she contributes to the Renewable Portfolio Standard (RPS)/ System Benefits Charge (SBC) through a monthly electric utility bill. Please email NYSERDA at PV@nyserdera.org regarding any questions, or to check the status of your application.

Customer Signature:  Date: 12-22-11

Print Name: Roxanne Marino; Supervisor, Town of Ulster

Eligible Installer: By signing below, the Installer certifies that he or she is: (1) Eligible to participate in NYSERDA's Incentive Program; (2) in compliance with Terms and Conditions of NYSERDA's program; and (3) is bound by the Terms and Conditions of this Customer Purchase Agreement.

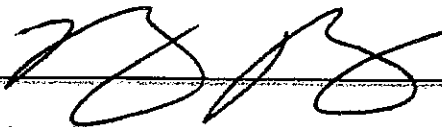
Eligible Installer Signature:  Date: 12/22/2011

Print Name: Nathan Rizzo

Affiliated Entity: By signing below, the Authorized Representative of the Eligible Installer's Affiliated Entity (Company) certifies that the Eligible Installer is working for said company and is in compliance with NYSERDA's Incentive Program. By signing below, the Company is bound by the Terms and Conditions of this Customer Purchase Agreement.

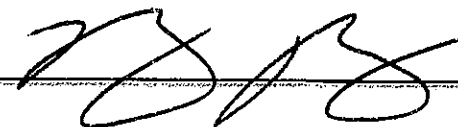
Authorized Company Signature:  Date: 12/22/2011

Print Name: Nathan Rizzo

**Solar Liberty Electric Company
Solar Equipment Lease**

Equipment Lease Number 240 dated as of December 19, 2011

Name and Address of Lessee:
Town of Ulysses
10 Elm St.
Trumansburg, NY 14886

Name and Address of Lessor:
Solar Liberty Electric Company, Inc.
6500 Sheridan Dr. Suite 120
Buffalo, NY 14221

EQUIPMENT DESCRIPTION AND SITE PLAN: SEE SCHEDULE A ATTACHED HERETO.

After Lessee signs this Lease, Lessee authorizes Lessor to insert any missing information or change any inaccurate information (such as the serial number for a module) into the Equipment Description.

EQUIPMENT LOCATION: 3888 Colegrove Rd., Trumansburg, NY 14886

SUMMARY OF PAYMENT TERMS	
Term (Months): 180 Months	Total Cost: \$22,500.00
Payment Frequency: Monthly	Total Net System Cost: \$115,710.00 (as set forth in the third column of Section 6 to the Installation Agreement).
Basic Rental Payment: See <u>Schedule B</u> plus applicable sales and use tax	Number of Installments: 180
Security Deposit: \$0.00	Cutoff Date: 1/11/2026
Lease Commencement Date is estimated to be on or before May 1, 2012 and shall occur upon passage of title from Installer to Owner pursuant to the Installation Agreement between the parties hereto and Solar Liberty Energy Systems, Inc. executed contemporaneously herewith ("Installation Agreement").	

THIS AGREEMENT INCLUDES THE TERMS ON THE FOLLOWING PAGES, SCHEDULES AND EXHIBITS ATTACHED HERETO.

Lessee: Town of Ulysses

Lessor: Solar Liberty Electric Company, Inc.

By: Koranne Marie

By: Adam K. Sizto

Title: Supervisor

Title: President

1. **LEASE.** Lessor hereby agrees to lease to Lessee, and Lessee hereby agrees to lease from Lessor, the personal property described on Schedule A to this Solar Equipment Lease (the "Lease") on the terms and conditions set forth herein (such property together with all replacements, substitutions, parts, improvements, repairs, and accessories and all additions incorporated therein or affixed thereto being referred to herein as the "Equipment"). Lessee's execution of this Lease shall obligate Lessee to lease the Equipment from Lessor. This Lease shall not be binding on Lessor unless and until executed by Lessor. Anything to the contrary notwithstanding, Lessor shall have no obligation to accept, execute or enter into this Lease or to acquire or lease to Lessee the Equipment. Title to the Equipment shall at all times remain in Lessor during the term of the Lease.

2. **SAVINGS GUARANTY.** Lessor agrees that the Basic Rental Payments for any annual lease period (months 1-12) plus the Lessee's Current Utility Payment (collectively, the "System Electricity Production Value") will not exceed the Lessee's Historic Utility Payment. "Current Utility Payment" shall be the total amount paid by Lessee to its electric utility provider (for the electricity consumption in the annual lease period corresponding to the basic rental payment), including any and all related rates, charges, surcharges, taxes, fees and penalties, for electricity consumed during the relevant annual lease period. "Historic Utility Payment" shall be the total amount paid by Lessee to its electric utility provider for electricity, including any and all related rates, charges, surcharges, taxes, fees and penalties, for the twelve (12) month period immediately preceding the Lease Commencement Date. If the System Electricity Production Value exceeds the Historic Utility Payment for the relevant annual period, the Lessor will refund the difference to the Lessee.

3. **TERM.** The "Lease Commencement Date" for this Lease shall be the date set forth below Lessor's signature hereto and the Lease shall continue for the Initial Term set forth above unless earlier terminated by Lessor as provided herein. At the expiration of the Initial Term, unless Lessee shall have renewed or purchased the Equipment from Lessor pursuant to Paragraph 16 or returned the Equipment to Lessor in accordance with Paragraph 17.

4. **RENT.** (a) Lessee shall pay as monthly basic rent for the Initial Term of this Lease the amount shown on the first page of this Lease and as set forth on Schedule B hereto ("Basic Rental Payment"), provided that the aggregate Basic Rent Payment paid by the Lessee during the Term shall be less than the Total Net System Cost, as set forth in the Summary of Payment Terms above. The Basic Rental Payment shall be payable in installments in the amounts and on the dates provided in Schedule B of this Lease, plus any applicable sales and use tax thereon; provided, however, that Lessor and Lessee may agree to any other payment schedule, in which event Schedule B shall be amended by Lessor to reflect the new payment schedule upon written notice from Lessor to Lessee.

5. **ENVIRONMENTAL FINANCIAL INCENTIVES AND ENVIRONMENTAL ATTRIBUTES.** All Environmental Financial Incentives and Environmental Attributes available in connection with the Equipment, other than those specifically assigned to NYSERDA pursuant to the Installation Agreement, are retained and owned by Lessor. Lessee shall take all reasonable measures to assist Lessor in obtaining all Environmental Financial Incentives currently available or subsequently made available in connection with the Equipment. If Lessee fails to act in good faith in taking actions reasonably requested by Lessor, and such failure results in the loss of an Environmental Financial Incentive that would otherwise be available, Lessee shall reimburse Lessor for the full amount of such lost Environmental Financial Incentive. For purposes of this Lease, (i) "Environmental Financial Incentive" means the following financial incentives that are in effect as of the Lease Commencement Date or may come into effect in the future: (i) federal, state or local tax credits (including investment tax credits arising under the Internal Revenue Code and grants in lieu thereof), other tax benefits or grants in lieu thereof (including without limitation the monetization of tax benefits), and (ii) all reporting rights with respect to such incentives; and (ii) "Environmental Attribute" means, without limitation: (i) tradable renewable certificates, green-e tags, allowances, reductions or other transferable indicia denoting carbon offset credits or indicating generation of a particular quantity of energy from a renewable energy source by a renewable energy facility attributed to the energy created by the Equipment during the Term created under a renewable energy, emission reduction, or other reporting program adopted by a governmental authority, or for which a registry and a market exists or for which a market may exist at a future time, (ii) performance-based incentives, rebates and any other incentives under any utility's or any state's solar program or initiative, and any other incentive, certificate, subsidy, award, grant or economic benefit, howsoever named or referred to, with respect to any and all fuel, emissions, air quality, energy generation, or other environmental or energy characteristics, resulting from the construction or operation of the Equipment or from the use of solar generation or the avoidance of the emission of any gas, chemical or other substance into the air, soil or water attributable to the sale of energy generated by the Equipment (other than Environmental Financial Incentives).

All contracts related to the sale of Environmental Attributes shall be collaterally assigned by Lessee to Lessor in accordance with Paragraph 6. If reasonably requested by Lessor, Lessee shall provide Lessor with acknowledgements from the counterparties to such contracts, acknowledging the collateral assignment of such contracts and Lessor's rights to such contracts.

6. **GRANT OF SECURITY INTEREST.** As collateral security for the payment and performance in full when due (whether at stated maturity, by acceleration or otherwise) of Lessee's obligations hereunder, Lessee hereby assigns, pledges and grants to Lessor, a security interest in, and continuing lien on all of Lessee's right, title and interest (if any) in, to and under the following, in each case whether tangible or intangible, wherever located, and whether now owned by Lessee or hereafter acquired and whether now existing or hereafter coming into existence (the "Collateral"): (i) the Lessee's leasehold interest in the Equipment, (ii) all agreements, existing or hereafter entered into by Lessee relating to the operation, maintenance or use and occupancy of the Equipment or the sale of Environmental Attributes, including without limitation, all instruments and documents executed and delivered with respect to such agreements, as the same may be amended, supplemented or otherwise modified from time to time in accordance with the terms thereof and this Lease (such agreements as so amended, supplemented or modified, being the "Project Documents"), including, without limitation, all rights of Lessee to receive moneys due and to become due under or pursuant to the Project Documents, including, without limitation, those agreements indicated on Schedule C hereof, any documents evidencing Lessee's claim to the state rebates, subsidies, or incentives applicable to the Equipment, (iii) Environmental Attributes and the electricity generated by the Equipment, and (iv) and all proceeds of the foregoing.

When Lessee's obligations hereunder have been paid in full, the security interests and liens granted pursuant to this Lease with respect to the Collateral shall terminate, all rights granted hereunder with respect to the Collateral shall revert back to Lessee, and Lessor shall, at the expense of Lessee, execute and deliver to Lessee upon such termination such termination statements and any other releases or terminations, reasonably requested by Lessee to effect the termination and release of the security interests.

7. **NO WARRANTIES.** THE EQUIPMENT IS LEASED "AS IS, WHERE IS". LESSEE ACKNOWLEDGES THAT: LESSOR IS NOT THE MANUFACTURER OR INSTALLER OF THE EQUIPMENT NOR THE MANUFACTURER'S AGENT NOR A DEALER THEREIN; THE EQUIPMENT IS OF A SIZE, DESIGN, CAPACITY, DESCRIPTION AND MANUFACTURE

SELECTED BY LESSEE; LESSEE IS SATISFIED THAT THE EQUIPMENT IS SUITABLE AND FIT FOR ITS PURPOSES; AND LESSOR HAS NOT MADE AND DOES NOT MAKE ANY WARRANTY WITH RESPECT TO THE EQUIPMENT, EXPRESS OR IMPLIED AND LESSOR SPECIFICALLY DISCLAIMS ANY WARRANTY OF MERCHANTABILITY OR OF FITNESS FOR A PARTICULAR PURPOSE, THE QUALITY, CONDITION OR CAPACITY OF THE EQUIPMENT OR THE MATERIALS IN THE EQUIPMENT OR WORKMANSHIP OF THE EQUIPMENT, LESSOR'S TITLE TO THE EQUIPMENT, NOR ANY OTHER REPRESENTATION OR WARRANTY WHATSOEVER. LESSOR SHALL NOT BE LIABLE TO LESSEE FOR ANY LOSS, DAMAGE, OR EXPENSE OF ANY KIND OR NATURE CAUSED, DIRECTLY OR INDIRECTLY, BY ANY EQUIPMENT OR THE USE OR MAINTENANCE THEREOF OR THE FAILURE OR OPERATION THEREOF, OR THE REPAIR, SERVICE OR ADJUSTMENT THEREOF, OR BY ANY DELAY OR FAILURE TO PROVIDE ANY SUCH MAINTENANCE, REPAIRS, SERVICE OR ADJUSTMENT, OR BY AN INTERRUPTION OF SERVICE OR LOSS OF USE THEREOF OR FOR ANY LOSS OF BUSINESS HOWSOEVER CAUSED. LESSOR SHALL NOT BE LIABLE FOR DAMAGES OF ANY KIND INCLUDING ANY LIABILITY FOR CONSEQUENTIAL, INDIRECT OR PUNATIVE DAMAGES ARISING OUT OF THE USE OF OR THE INABILITY TO USE THE EQUIPMENT.

No defect or unfitness of the Equipment, or any failure on the part of the manufacturer or the shipper of the Equipment to deliver the Equipment or any part thereof to Lessee shall relieve Lessee of the obligation to pay rent or any other obligation hereunder. To the extent permitted by the manufacturer and/or vendor and provided Lessee is not in default under the Lease, Lessor shall make available to Lessee all manufacturer and/or vendor warranties with respect to the Equipment, and Lessee shall, and hereby is authorized during the Term, to assert and enforce, at Lessee's sole risk, cost and expense, from time to time, in the name of and for the account of Lessor and/or Lessee, as their interests may appear, but without prejudice to Lessor, whatever claims and rights Lessee and/or Lessor may have against any manufacturer or supplier of the equipment comprising the Equipment.

8. COVENANTS.

(a) Affirmative Covenants. Lessee shall: (i) comply with all applicable laws and regulations and rules; and with the conditions and requirements of all policies of insurance relating to the Equipment and its use; (ii) at any and all times during business hours, grant Lessor free access to enter upon the premises wherein the Equipment shall be located or used and permit Lessor to inspect the Equipment; (iii) cooperate with the Lessor to do all things necessary to preserve, renew and keep in full force and effect all necessary consents, approvals and authorizations with governmental authorities and nongovernmental persons required in connection with this Lease and the use of the Equipment; (iv) if requested by Lessor, obtain an acknowledgment by the counterparty of any agreement related to the sale or receipt of any Environmental Attribute of the collateral assignment of Lessee's rights in such agreement; and (viii) provide Lessor with thirty (30) days notice in event of a change in ownership or title of the premises wherein the Equipment is located.

(b) Negative Covenants. Lessee shall not (i) voluntarily or involuntarily create, incur, assume or suffer to exist any mortgage, lien, security interest, pledge or other encumbrance or attachment of any kind whatsoever upon, affecting or with respect to the Equipment, the Collateral, this Lease or any of Lessee's interests thereunder; (ii) permit the name of any person, association or corporation other than Lessor or Lessee to be placed on the Equipment; (iii) part with possession or control of or suffer or allow to pass out of its possession or control any item of the Equipment or change the location of the Equipment or any part thereof from the address shown above; (iv) ASSIGN OR IN ANY WAY DISPOSE OF ALL OR ANY PART OF ITS RIGHTS OR OBLIGATIONS UNDER THIS LEASE OR ENTER INTO ANY SUBLEASE OF ALL OR ANY PART OF THE EQUIPMENT; (v) cause the Equipment to be permanently taken out of service; (vx) amend, waive, or violate any of the material terms of any Project Document; or (vi) assign, sell, transfer or in any way convey its right, duties or obligations under the Lease, without the prior written consent of the Lessor, which consent shall not be unreasonably withheld or delayed.

9. **TAXES.** Lessee shall promptly pay when due all sales, use, property, excise and other taxes (including, without limitation, income taxes collected by deduction or withholding) and all license and registration fees now or hereafter imposed by any governmental body or agency upon the Equipment or its use, purchase, ownership, delivery, leasing, possession, storage, operation, maintenance, repair, return or other disposition of the Equipment, or for titling or registering the Equipment, or upon the income or other proceeds received with respect to the Equipment or Lease or the rentals hereunder; provided, however, that Lessee shall not be required to pay taxes on or measured by the net income of Lessor. Upon request by Lessor, Lessee shall prepare and file all tax returns relating to taxes for which Lessee is responsible hereunder which Lessee is permitted to file under the laws of the applicable taxing jurisdiction.

10. **INDEMNITY.** Lessee hereby agrees to indemnify and hold Lessor harmless from and against any and all claims, losses, liabilities, damages, judgments, suits and all legal proceedings, and any and all costs and expenses in connection therewith (including attorneys' fees) arising out of or in any manner connected with this Lease, including without limitation, claims for injury to or death of persons and for damage to property, including without limitation, any claims based in negligence, strict liability in tort, environmental indemnity, or intellectual property infringement. Lessee shall give Lessor prompt notice of any such claim or liability.

11. **ASSIGNMENT.** Lessor may assign its interest in this Lease and sell or grant a security interest in all or any part of the Equipment without notice to or the consent of Lessee. Lessee agrees not to assert against any assignee of Lessor any claim or defense Lessee may have against Lessor. In the event of a change in ownership or title of the premises wherein the Equipment is located, Lessee may assign this Lease, upon written notice to Lessor, to the new owner of the Premises, provided that such new owner shall agree in writing to assume this Lease, and Lessee shall reimburse Lessor for any loss of Environmental Financial Incentives or Environmental Attributes.

12. **EQUIPMENT PERSONALTY.** This Lease is and is intended to be a lease of personal property for all purposes. The Equipment shall remain personal property regardless of its attachment to realty, and Lessee agrees to take such action at its expense as may be necessary to prevent any third party from acquiring any interest in the Equipment as a result of its attachment to realty. If requested by Lessor, with respect to any item of Equipment, Lessee will obtain and deliver to Lessor waivers of interest or liens in recordable form, satisfactory to Lessor, from all persons claiming any interest in the real property on which the Equipment is installed or located.

13. **USE AND MAINTENANCE.** Lessee will use the Equipment with due care and for the purpose for which it is intended. Lessor shall, at Lessor's cost and expense, operate, maintain, service and repair the Equipment in good operating order, repair and condition for the full term of the lease, ordinary wear and tear excepted. Lessor may, at its sole discretion cause a third-party operator to provide the services described in this Paragraph 13. All parts, modifications and improvements to the Equipment shall, when installed or made, immediately remain the property of Lessor and part of the Equipment for all purposes.

14. **LOSS OR DAMAGE.** Except as a result of Lessor's actions, Lessee assumes all risk of any damage to or loss, theft, confiscation or destruction of the Equipment from any cause whatsoever from the Lease Commencement Date through the end of the Term. Lessee shall advise Lessor in writing promptly of any loss or damage to the Equipment and the circumstances and extent of such damage.

15. INSURANCE. Lessee shall obtain and maintain on or with respect to the Equipment at its own expense (a) liability insurance insuring against liability for bodily injury and property damage, and (b) all-risk physical damage insurance (including without limitation catastrophic risks) insuring against loss or damage to the Equipment in an amount not less than Termination Value. Lessee shall furnish Lessor with a certificate of insurance evidencing the issuance of a policy or policies naming Lessor as an additional insured thereunder for the liability coverage and as loss payee for the property damage coverage. Each such policy shall be in such form and with such insurers as may be satisfactory to Lessor, shall insure Lessor's interest, regardless of any breach or violation by Lessee of any warranties, declarations or conditions in such policies; and shall contain a clause requiring the insurer to give to Lessor at least 10 days prior written notice of (i) the cancellation of such policy or (ii) any amendment to the terms of such policy if such amendment would cause the policy no longer to conform to the policy requirements stated in this Paragraph 15. Lessor shall be under no duty to ascertain the existence of or to examine any such policy or to advise Lessee in the event any such policy shall not comply with the requirements hereof. In the event that Lessee shall fail to obtain the insurance required under this Paragraph 15, Lessor may obtain insurance in accordance with this Paragraph and Lessee shall be required to reimburse Lessor for all reasonable fees and expenses, including insurance premiums, in connection therewith.

16. END OF TERM. Upon expiration of the Initial Term of the Lease and, except as otherwise specifically set forth herein, any renewal term, and, provided that the Lease has not been terminated early and Lessee is in compliance with the Lease in all respects and no Event of Default has occurred and is continuing, Lessee may upon at least 180 days and not more than 365 days prior written notice to Lessor exercise one of the following options:

- (i) purchase all (but not less than all) of the Equipment for a purchase price equal to the then Fair Market Value of the Equipment. Upon such indefeasible payment, Lessor will transfer to Lessee, on an AS IS BASIS (free and clear of any liens attributable to Lessor), all of Lessor's interest in and to the Equipment and shall release its lien on the applicable Collateral. Lessee shall pay any sales and use taxes due on such transfer. Lessor shall not be required to make and may specifically disclaim any representation or warranty as to the condition of such Equipment and other matters (except that Lessor shall warrant that it has conveyed whatever interest it received in the Equipment from Lessee, free and clear of any liens attributable to Lessor). At Lessee's expense, Lessor shall promptly execute and deliver to Lessee such statements of termination, as reasonably may be required in order to release or terminate any interest of Lessor in and to the Equipment and the Collateral and perform such other actions as Lessee may reasonably request to effectuate the foregoing; or
- (ii) renew the Lease with respect to all of the Equipment at the expiration of the Initial Term for the then Fair Market Rental Value of the Equipment for a term to be agreed upon by Lessee and Lessor. "Fair Market Rental Value" of the Equipment for purposes of the preceding sentence shall be an amount determined according to the following procedure. Upon receipt of Lessee's notice of election to renew the Lease, Lessee and Lessor will attempt to agree on an amount during the next 30 days, and the amount so agreed upon shall be the Fair Market Rental Value. In the event Lessor and Lessee cannot agree on an amount during such 30-day period, then each party shall choose an independent appraiser, and the two appraisers shall each determine the Fair Market Rental Value of the Equipment on the basis of an arm's-length transaction between an informed and willing lessor and an informed and willing lessee under no compulsion to lease. The average of the amounts determined by the two appraisers shall be the Fair Market Rental Value. Each party shall pay the expenses of the appraiser it chooses; or
- (iii) return the Equipment to Lessor in accordance with paragraph 17 of the Lease.

17. RETURN OF THE EQUIPMENT. Upon the expiration or earlier termination of this Lease by Lessor (unless Lessee purchases the Equipment pursuant to paragraph 16), Lessee shall return the Equipment to Lessor in accordance with (i) or (ii) below.

- (i) Lessor shall arrange for the de-installation and disassembly and packing of the Equipment, together with all parts and pieces and then reinstallation and reassembly (including, if necessary, repair and overhaul) at its sole cost and expense. Lessee agrees to cooperate with the Lessor in all respects in order to make arrangements with respect to such de-installation and disassembly of the Equipment and to ensure that all Equipment subject to the Lease shall be returned to the Lessor in a manner consistent with prudent industry standards.
- (ii) Per Lessor's instructions, Lessee shall surrender the Equipment to Lessor installed and in use at the Equipment Location set forth above, free and clear of any rights or interests of Lessee and Lessor (or a qualified third-party satisfactory to Lessor) shall operate and maintain the Equipment at the Equipment Location and Lessee shall continue to grant Lessor access rights pursuant to the terms hereof

18. ADDITIONAL ACTION; EXPENSES. Lessee will promptly execute and deliver to Lessor such further documents and take such further action as Lessor may request in order to carry out more effectively the intent and purpose of this Lease. Lessor and any assignee of Lessor is authorized to file one or more Uniform Commercial Code financing statements without the signature of Lessee or signed by Lessor or any assignee of Lessor as attorney-in-fact for Lessee. If Lessee fails to perform or comply with any of its agreements, Lessor may perform or comply with such agreements in its own name or in Lessee's name as attorney-in-fact and the amount of any payments and expenses of Lessor incurred in connection with such performance or compliance, together with interest thereon at the rate provided below, shall be deemed rent payable by Lessee upon demand.

19. LATE CHARGES. If any payment, whether for rent or otherwise, is not paid when due, Lessor may impose a late charge of up to 5% of the amount past due (or the maximum amount permitted by applicable law, if less). Payments thereafter received shall be applied first to delinquent installments and then to current installments.

20. DEFAULT. Each of the following events shall constitute an "Event of Default" hereunder: (a) Lessee shall fail to pay when due any installment of basic rent or other amount under the Lease; (b) Lessee shall fail to observe or perform any other agreement to be observed or performed by Lessee hereunder and the continuance thereof for 10 calendar days following written notice thereof by Lessor to Lessee; (c) Lessee shall cease doing business as a going concern or make an assignment for the benefit of creditors; (d) Lessee shall voluntarily file, or have filed against it involuntarily, a petition for liquidation, reorganization, adjustment of debt, or similar relief under the federal Bankruptcy Code or any other present or future federal or state bankruptcy or insolvency law, or a trustee, receiver, or liquidator shall be appointed of it or of all or a substantial part of its assets; (e) an event of default shall occur under any other obligation Lessee owes to Lessor; (f) an event of default shall occur under any indebtedness Lessee may now or hereafter owe to any affiliate of Lessor; (g) any representation, warranty or statement made by Lessee in connection with the Lease (including any statements or information provided by

Lessee in connection with Lessor's application under Section 1603 of the American Recovery and Reinvestment Act of 2009 for cash payments in lieu of tax credits for the Equipment) shall be untrue or misleading in any material respect as of the date the same was delivered to Lessor; or (h) the Lease fails to provide Lessor with security interests in the Collateral and Lessee fails to remedy such event.

21. REMEDIES. Lessor may exercise any other right or remedy available to it by law or by agreement, and may in any event recover legal fees and other expenses incurred by reason of an Event of Default or the exercise of any remedy hereunder. Lessor shall have all of the rights and remedies with respect to the Collateral of a secured party under the applicable Uniform Commercial Code and such additional rights and remedies to which a secured party is entitled. No remedy given in this Paragraph 21 is intended to be exclusive, and each shall be cumulative but only to the extent necessary to permit Lessor to recover amounts for which Lessee is liable hereunder. No express or implied waiver by Lessor of any breach of Lessee's obligations hereunder shall constitute a waiver of any other breach of Lessee's obligations hereunder.

22. NOTICES. Any written notice hereunder to Lessee or Lessor shall be deemed to have been given when delivered personally or deposited with a recognized overnight courier service or in the United States mail, postage prepaid, addressed to recipient at its address set forth on the first page of this Lease or at such other address as may be last known to the sender.

23. NET LEASE AND UNCONDITIONAL OBLIGATION. This Lease is a completely net lease and Lessee's obligation to pay rent and amounts payable by Lessee hereunder is unconditional and irrevocable and shall be paid without any abatement, reduction, setoff or defense of any kind.

24. NON-CANCELABLE LEASE. This Lease cannot be canceled or terminated except as expressly provided herein.

25. SURVIVAL OF INDEMNITIES. Lessee's obligations under Paragraphs 9, 10 and 21 shall survive termination or expiration of this Lease.

26. COUNTERPARTS. There shall be but one counterpart of this Lease and such counterpart will be marked "Original." To the extent that this Lease constitutes chattel paper (as that term is defined by the Uniform Commercial Code), a security interest may only be created in the Lease marked "Original."

27. NON-WAIVER. No course of dealing between Lessor and Lessee or any delay or omission on the part of Lessor in exercising any rights hereunder shall operate as a waiver of any rights of Lessor. A waiver on any one occasion shall not be construed as a bar to or waiver of any right or remedy on any future occasion. This Lease is a net lease and a "finance lease" under Article 2A of the Uniform Commercial Code. To the extent permitted by applicable law, Lessee hereby waives any and all rights and remedies conferred upon a Lessee by Article 2A-508 through 2A-522 of the Uniform Commercial Code, including but not limited to Lessee's rights to: (i) cancel this Lease; (ii) repudiate this Lease; (iii) reject the Equipment; (iv) revoke acceptance of the Equipment; (v) recover damages from Lessor for any breaches of warranty or for any other reason; (vi) claim a security interest in the Equipment in Lessee's possession or control for any reason; (vii) deduct all or any part of any claimed damages resulting from Lessor's default, if any, under this Lease; (viii) accept partial delivery of the Equipment; (ix) "cover" by making any purchase or lease of or contract to purchase or lease Equipment in substitution of Equipment identified to this Lease; (x) recover any general, special, incidental, or consequential damages, for any reason whatsoever; and (xi) specific performance, replevin, detinue, sequestration, claim, delivery or the like for the Equipment identified to this Lease. To the extent permitted by applicable law, Lessee also hereby waives any rights now or hereafter conferred by statute or otherwise which may require Lessor to sell, lease or otherwise use any Equipment in mitigation of Lessor's damages as set forth in Paragraph 21 or which may otherwise limit or modify any of Lessor's rights or remedies under Paragraph 21. Notwithstanding the foregoing and any other provision of this lease, in the event that the Lessor breaches the terms of this lease, the Lessee shall have the following remedies: Specific performance and/or compensatory damages.

28 REPRESENTATIONS AND AGREEMENTS. Lessee hereby represents and agrees that:

(a) effective on the date on which Lessee executes this Lease: (i) if Lessee is an entity, the execution and delivery of this Lease and the performance of Lessee's obligations hereunder have been duly authorized by all necessary action on the part of Lessee; (ii) the person signing the Lease on behalf of Lessee is duly authorized; (iii) all information provided by Lessee to Lessor in connection with this Lease is true and correct; and (iv) this Lease constitutes a legal, valid and binding obligation of Lessee, enforceable against Lessee in accordance with its terms;

(b) the Lease will not violate Lessee's organizational documents (if applicable) and will not violate or result in a default under any agreement or other instrument binding upon Lessee;

(c) Lessee (i) complies with, and will continue to comply with, all applicable environmental laws with respect to the Equipment Location, (ii) is not subject to any environmental liability with respect to the Equipment Location, (iii) does not know of any fact, circumstance or condition with respect to the Equipment Location that would reasonably be expected to result in an environmental claim;

(d) Lessee has provided Lessor with true, correct, and complete copies of the Project Documents;

(e) Lessee is not, and will not become, as a result of Lessee's execution, delivery or performance of this Lease, subject to regulation (i) under the FPA, the Public Utility Regulatory Policies Act of 1978 ("PURPA") or Public Utility Holding Company Act of 2005 ("PUHCA 2005"), each as amended, or any regulations thereunder or (ii) as an "electrical corporation," "public utility" or the equivalent under any applicable state law, as amended, or other applicable law;

(f) Lessee is the sole owner of the Collateral (other than the Equipment), has good and valid title to such Collateral, including all right, title and interest therein, free and clear of all liens;

(g) Lessee has granted to Lessor a perfected first priority lien on and security interest in the Collateral in which a security interest may be created under Article 9 of the New York Uniform Commercial Code; and

(h) neither Lessee, nor to Lessee's knowledge, any affiliate of the Lessee (i) appear on the OFAC SDN List; (ii) are included in, owned by, controlled by, acting for or on behalf of, providing assistance, support, sponsorship, or services of any kind to, or otherwise associated with any of the persons or entities referred to or described in the OFAC SDN List; or (iii) have conducted business with or engaged in any transaction with any person or entity named on any of the OFAC SDN List or any person or

entity included in, owned by, controlled by, acting for or on behalf of, providing assistance, support, sponsorship, or services of any kind to, or otherwise associated with any of the persons or entities referred to or described in the OFAC SDN List. For purposes of this Lease, "OFAC SDN List" means the list of "Specially Designated Nationals and Blocked Persons" maintained by the United States Department of Treasury Office of Foreign Assets Control.

29. TAX REPRESENTATIONS AND AGREEMENTS. Lessee represents, warrants and agrees that:

(a) neither Lessee (nor any of its affiliates) has claimed or will claim that Lessee is the owner of the Equipment or any portion thereof or that Lessee is otherwise entitled to all or any of the Environmental Financial Incentives except as authorized by the Lessor, and neither Lessee nor any of its Affiliates will file any tax return or take any position that is inconsistent with the treatment of Lessor as the owner of the Equipment or any portion thereof;

(b) Lessee has not previously assigned to any other party any rights to the Environmental Financial Incentives, and Lessee has no knowledge that any other party has a right or has claimed a right to all or any part of the Environmental Financial Incentives;

(c) Lessee will provide to Lessor (or its designee) on a timely basis any documentation required to support eligibility for and to establish the amount of any grants in lieu of tax credits that Lessor may claim;

(e) following submission of any application by Lessor for grants in lieu of tax credits, Lessee will provide to Lessor (or its designee) on a timely basis any documentation required to demonstrate that the Equipment remains eligible for the grants and such other documents as Lessor or the United States Department of the Treasury ("Treasury") may request;

(f) all information that Lessee has provided to Lessor pursuant to this Lease is or will be true and accurate in all material respects, and Lessee will promptly inform Lessor if Lessee determines that any such information was materially inaccurate or incorrect; and

(g) Lessee shall execute and deliver such other certificates and other documents and take such other actions as may be reasonably requested by Lessor in furtherance of grants in lieu of tax credits that Lessor will claim with respect to the Equipment

30. MISCELLANEOUS. This Lease and the Installation Agreement constitute the entire agreement between Lessor and Lessee and may be modified only by a written instrument signed by Lessor and Lessee. Any provision of this Lease that is unenforceable in any jurisdiction shall, as to such jurisdiction, be ineffective to the extent of such unenforceability without invalidating the remaining provisions of this Lease, and any such unenforceability in any jurisdiction shall not render unenforceable such provision in any other jurisdiction. Paragraph headings are for convenience only, are not part of this Lease and shall not be deemed to effect the meaning or construction of any of the provisions hereof. In the event there is more than one Lessee named in this Lease, the obligations of each shall be joint and several. Lessor may in its sole discretion, accept a photocopy, electronically transmitted facsimile or other reproduction of this Lease (a "Counterpart") as the binding and effective record of this Lease whether or not an ink signed copy hereof is also received by Lessor from Lessee, provided, however, that if Lessor accepts a Counterpart as the binding and effective record hereof, the Counterpart acknowledged in writing above by Lessor shall constitute the record hereof. Lessee agrees that such Counterpart received by Lessor, shall, when acknowledged in writing by Lessor, constitute an original document for the purposes of establishing the provisions thereof and shall be legally admissible under the best evidence rule and binding on and enforceable against Lessee. If Lessor accepts a Counterpart as the binding and effective record hereof only such Counterpart acknowledged in writing above by Lessor shall be marked "Original" and to the extent that this Lease constitutes chattel paper, a security interest may only be created in the Lease that bears Lessor's ink signed acknowledgement and is marked "Original." This Lease shall in all respects be governed by, and construed in accordance with, the substantive laws of the state of New York, and the Parties (i) agree that any disputes arising under this Lease shall be adjudicated by a judge of the court having jurisdiction and shall be venued in Erie County, New York and (ii) waive any right they may have to a jury trial of any claim or cause of action based on or arising out of this Lease.

TIME IS OF THE ESSENCE WITH RESPECT TO THE OBLIGATIONS OF LESSEE UNDER THIS LEASE.

Schedule A
Description of Equipment

<i>Specifications:</i>	
<i>Site Address</i>	<i>3888 Colegrove Rd., Trumansburg, NY 14886</i>
<i>System Size (Capacity)</i>	<i>24.36kW</i>
<i>Estimated year 1 Production</i>	<i>23,560kWh</i>
<i>System Design</i>	<i>Qty (116) Solar Modules; Qty (4) SMA Inverter</i>
<i>Delivery Point</i>	<i>Main Distribution Panel</i>
<i>Design Install</i>	<i>See below for site plan and system layout</i>

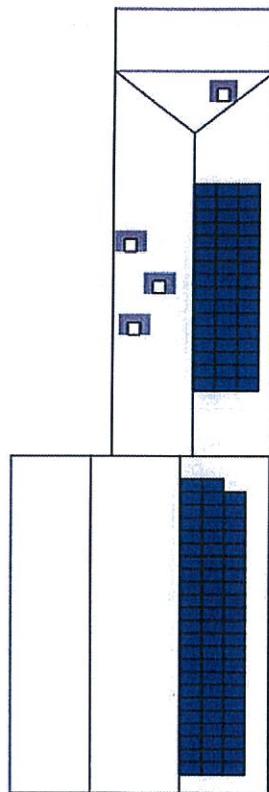

0' 10' 20'

Schedule B
Basic Rent Schedules

Month	Estimated kWh	Estimated Electrical Savings	Monthly Pmt.	Estimated Total Cost Savings
January	952	\$95.20	\$125.00	-\$29.80
February	1217	\$121.70	\$125.00	-\$3.30
March	2011	\$201.10	\$125.00	\$76.10
April	2488	\$248.80	\$125.00	\$123.80
May	3104	\$310.40	\$125.00	\$185.40
June	2984	\$298.40	\$125.00	\$173.40
July	3128	\$312.80	\$125.00	\$187.80
August	2710	\$271.00	\$125.00	\$146.00
September	2054	\$205.40	\$125.00	\$80.40
October	1424	\$142.40	\$125.00	\$17.40
November	748	\$74.80	\$125.00	-\$50.20
December	740	\$74.00	\$125.00	-\$51.00
	23560	\$2,356.00	\$1,500.00	\$856.00

1. Lessor shall not be liable for any delay or impairment of performance resulting in whole or in part from Acts of God, severe weather conditions, labor disruptions, governmental decrees or controls, insurrections, war risks, shortages, inability to procure or ship product or obtain permits and licenses, supplies of materials, or any other circumstances or causes beyond the control of Lessor in the conduct of its business.
2. Estimated Electrical Savings is contingent upon customer's current cost per kWh (\$/kWh) from the utility company and is not a guaranty by Lessor.

Schedule C
Project Documents

- (i) any renewable energy credit sales agreement;
- (ii) the interconnection agreement;
- (iii) module warranties; and
- (iv) inverter warranties.



6500 Sheridan Dr. Suite 120
Buffalo NY 14221
866-80-RENEW

PROJECT TITLE:

Town of Ulysses
Town Barn
3888 Colegrove Rd.
Trumansburg, NY 14886

SHEET TITLE:
Bird's Eye View

PV System Configuration:

System Size: 24.36kW

Solar Module: Evergreen210W

Number of Modules: 116

String Size: 17M x 6S
& 14M x 1S

Inverter: 3 x SMA7000W
& 1 x SMA3000W

Roof Area: 2040SQFT

Pitch of Roof: 4:12

Module Orientation: 90Degree

Drawn by: Ram

Sheet NO: 5-1

Date: 11-17-2011



South View



East View

This information is confidential and proprietary to Solar Liberty Energy Systems, Inc.
Please do not share this with anyone unless there is a written approval from Solar Liberty.

SOLARLIBERTY™
THE FUTURE OF ENERGY INDEPENDENCE.
6500 Sheridan Dr. Suite 120
Buffalo NY 14221
866-80-RENEW

PROJECT TITLE:

Town of Ulysses
Town Barn
3888 Colegrove Rd.,
Trumansburg, NY 14886

SHEET TITLE:
Roof Plan

Drawn by: Ram

Sheet NO: 5-2

Date: 11-17-2011

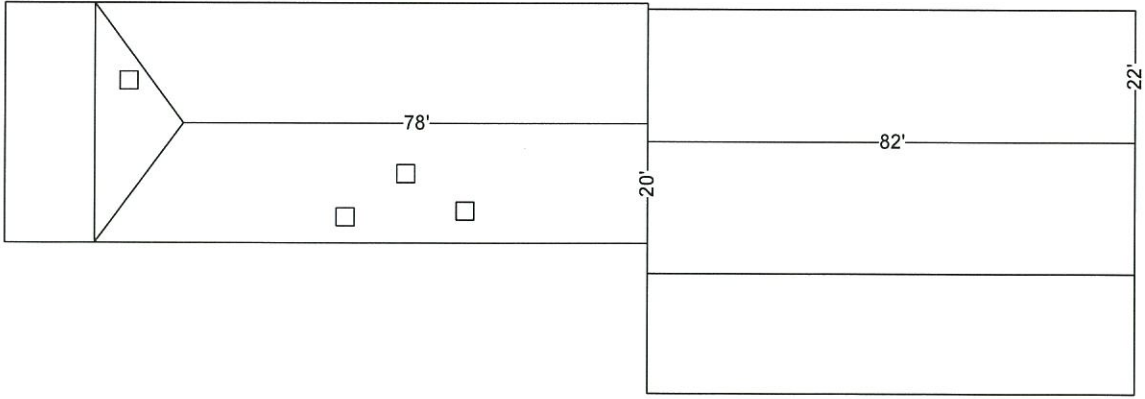



6500 Sheridan Dr. Suite 120
Buffalo NY 14221
866-80-RENEW

PROJECT TITLE:

Town of Ulysses
Town Barn
3888 Colegrove Rd.,
Trumansburg, NY 14886

SHEET TITLE:
Penetration & Shading

Shading



Drawn by: Ram

Sheet NO: 5-3

Date: 11-17-2011

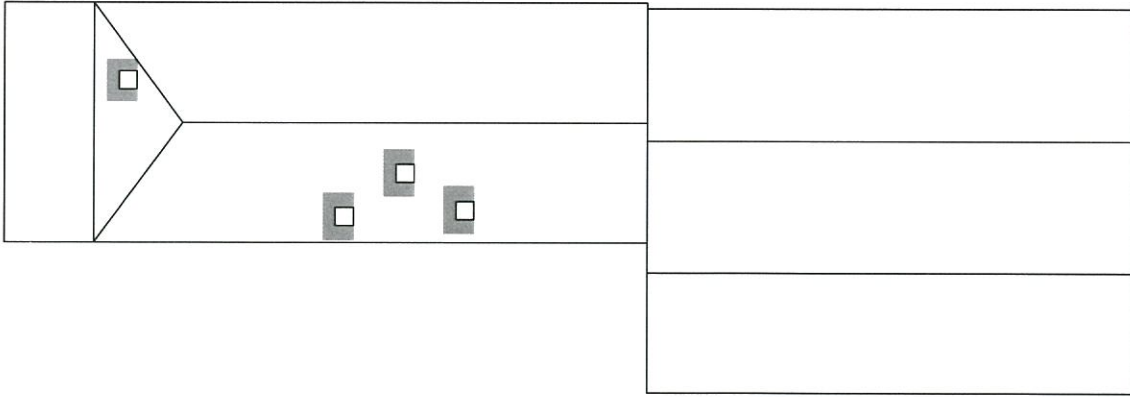

PROJECT TITLE:

Town of Ulysses
 Town Barn
 3888 Colegrove Rd.,
 Trumansburg, NY 14886

SHEET TITLE:

Solar Module Layout

PV System Configuration:

System Size: 24.36kW
Solar Module: Evergreen210W
Number of Modules: 116
String Size: 17M x 6S
 & 14M x 1S
Inverter: 3 x SMA7000W
 & 1 x SMA3000W
Roof Area: 2040SQFT
Pitch of Roof: 4:12

Module Info:

 65" x 37.5" x 1.8"

Drawn by: Ram

Sheet NO: 5-4

Date: 11-17-2011

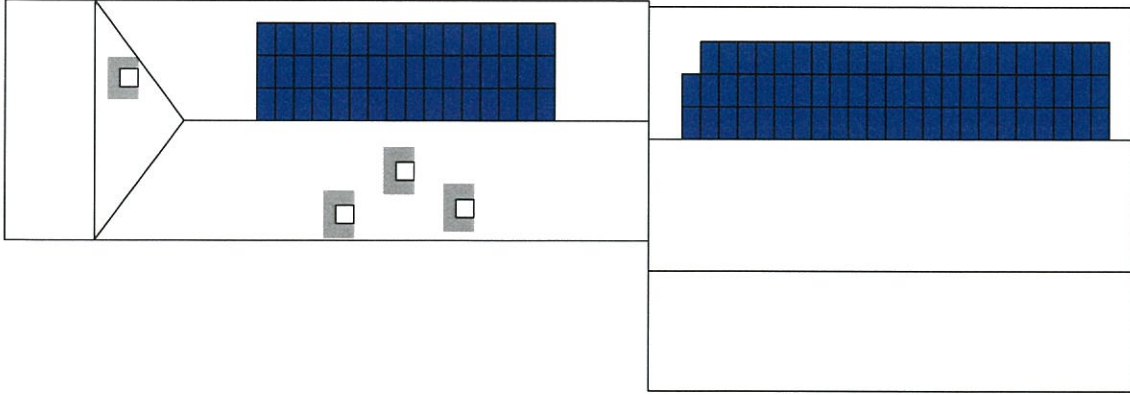





PROJECT TITLE:

Town of Ulysses
 Town Barn
 3888 Colegrove Rd.,
 Trumansburg, NY 14886

SHEET TITLE:
 Equipment Layout

EQUIPMENT INFO:

-  Inverters
-  Easy to Read Meter
-  Main Breaker Panel
-  Utility Meter

Drawn by: Ram

Sheet NO: 5-5

Date: 11-17-2011

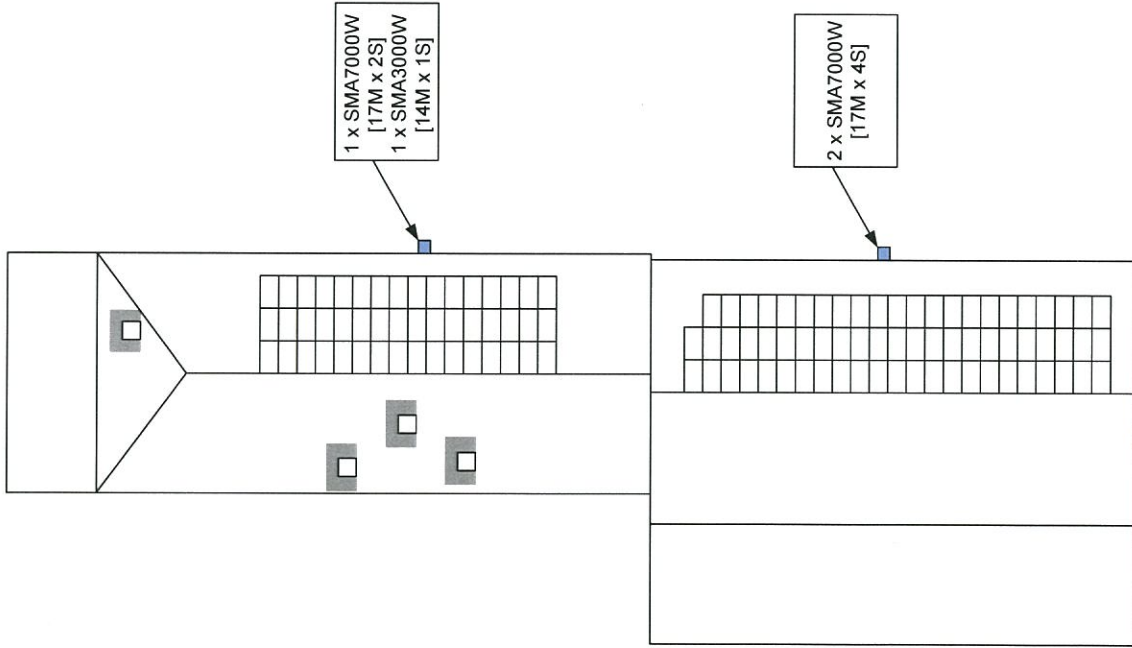

General Notes	
Array Details	
Panel Manufacturer:	Evergreen
Panel Model:	ES-A-210
Panel Count:	118
Array Dimensions:	174 x 85
	144 x 15
Inverter Details	
Inverter Model:	SB7000US
Inverter Power Rating:	700W max
Line-to-Line Voltage:	208V/1 ϕ
Inverter Model:	SB3000US
Inverter Power Rating:	3000W max
Line-to-Line Voltage:	208V/1 ϕ

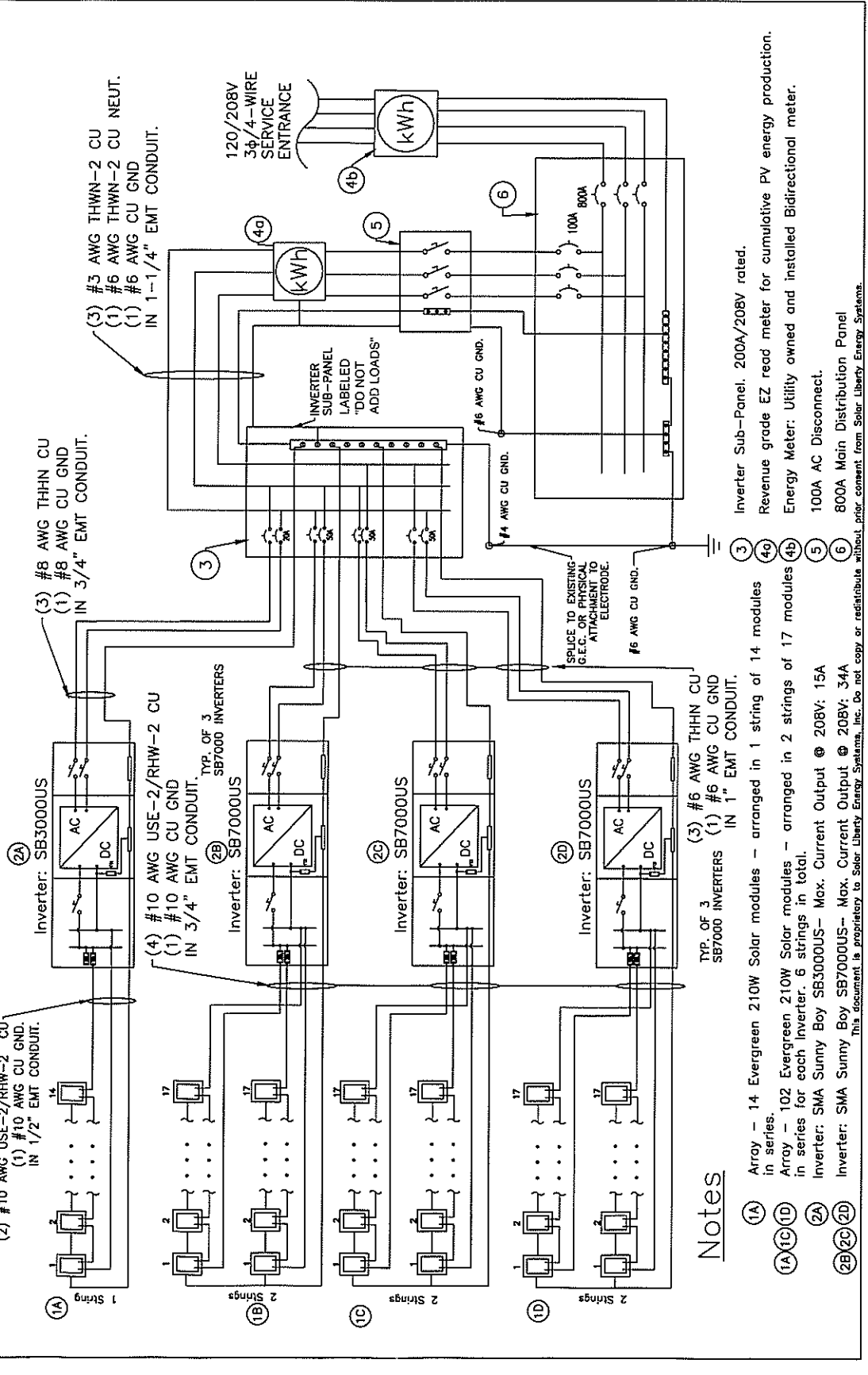

Notes

- (1A) Array - 14 Evergreen 210W Solar modules - arranged in 1 string of 14 modules in series.
- (1B) Array - 102 Evergreen 210W Solar modules - arranged in 2 strings of 17 modules in series for each inverter. 6 strings in total.
- (2A) Inverter: SMA Sunny Boy SB3000US-- Max. Current Output @ 208V: 15A
- (2B) Inverter: SMA Sunny Boy SB7000US-- Max. Current Output @ 208V: 34A
- (3) This document is proprietary to Solar Liberty Energy Systems, Inc. Do not copy or redistribute without prior consent from Solar Liberty Energy Systems.
- (4) Inverter Sub-Panel, 200A/208V rated.
- (5) Revenue grade EZ read meter for cumulative PV energy production.
- (6) Energy Meter: Utility owned and installed Bidirectional meter.
- (7) 100A AC Disconnect.
- (8) 800A Main Distribution Panel



**AC ENERGY
&
COST SAVINGS**



Ulysses Town Barn 24.36 kW

Station Identification	
City:	Buffalo
State:	New_York
Latitude:	42.93° N
Longitude:	78.73° W
Elevation:	215 m
PV System Specifications	
DC Rating:	24.4 kW
DC to AC Derate Factor:	0.800
AC Rating:	19.5 kW
Array Type:	Fixed Tilt
Array Tilt:	18.0°
Array Azimuth:	90.0°
Energy Specifications	
Cost of Electricity:	14.5 ¢/kWh

Results			
Month	Solar Radiation (kWh/m ² /day)	AC Energy (kWh)	Energy Value (\$)
1	1.53	866	125.57
2	2.26	1252	181.54
3	3.44	2096	303.92
4	4.44	2559	371.06
5	5.61	3200	464.00
6	5.94	3208	465.16
7	5.74	3137	454.87
8	5.07	2810	407.45
9	3.62	1950	282.75
10	2.59	1455	210.97
11	1.47	763	110.64
12	1.26	673	97.59
Year	3.59	23970	3475.65

[Output Hourly Performance Data](#)

*

[Output Results as Text](#)

[ABOUT THE HOURLY PERFORMANCE DATA](#)

[SAVING TEXT FROM A BROWSER](#)

RUN [PVWATTS v.1](#) FOR ANOTHER US LOCATION OR AN INTERNATIONAL LOCATION
 RUN [PVWATTS v.2](#) (US ONLY)

Please send questions and comments regarding PVWATTS to [Webmaster](#)

